

External venetian blinds from Griesser. Grinotex®



WIDTH

min. 600 mm, crank drive
min. 800 mm, gearbox in slat area
min. 760 mm, motor drive
min. 825 mm with operating position
max. 4000 mm

HEIGHT

min. 380 mm
max. 4250 mm

SURFACE AREA

max. 8 m², single blind
max. 24 m², connected systems with motor drive

TECHNOLOGY IN DETAIL

- 1 Self-supporting blind system as built-in or protruding system.
- 2 Guide rail with integrated lifting mechanism.
- 3 Slim slat profile, easy to clean.
- 4 Slat support connection: stainless steel wire cable coated with UV-stable plastic.
- 5 Plastic sealing lip.
- 6 Lifting chain and drive chain made from steel.
- 7 Guide pin at all slat ends.
- 8 Robust end rail made from extruded aluminum.

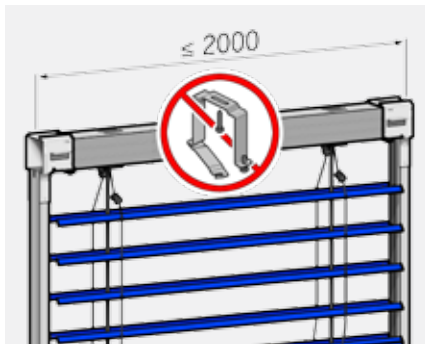

Self-supporting, no extra fasteners – easy on the insulation and simple to mount.



EXTERNAL VENETIAN BLIND WITH METAL JOINTS FOR DURABILITY





Safety locking device in each position.



Safety sensing edge.



Operating position (option)

LIMIT DIMENSIONS

bk Width of construction (rear edge of guide rails)

Minimum	
crank drive	600
gearbox in slat area	800
motor drive	760
operating position	825
Maximum	
	4000

Buildings and high-rise structures which are exposed to high wind should decrease this maximum value as required (see operating instructions).

hl Opening height

Minimum	380
Maximum	4250

bk × hl Maximum surface area

Single blind	
with crank drive	8 m ²
with motor drive	8 m ²
Connected systems (Max. system width 10 m)	
with crank drive	
2 blinds	8 m ²
3 blinds (max.)	6.5 m ²
In the case of 3 connected blinds, the drive should be positioned between two blinds.	
With motor drive	
2 blinds	16 m ²
3–4 blinds (max.)	24 m ²

For 3 or 4 blinds, the motor should be positioned in the center.

Header dimensions (hs)

hl	bk ≤									
	2000	2250	2500	2750	3000	3250	3500	3750	4000	
≤ 1250	230	230	230	245	245	245	255	255	255	
1251–1500	245	245	245	260	260	260	275	275	275	
1501–1750	265	265	280	280	280	290	290	290	290	
1751–2000	280	280	295	295	295	310	310	310	310	
2001–2250	300	300	315	315	315	325	325	325	325	
2251–2500	315	315	330	330	345	345	345	345		
2501–2750	335	335	350	350	360	360				
2751–3000	350	365	365	365	380					
3001–3250	370	385	385	385						
3251–3500	390	405	405							
3501–3750	410	425	425							
3751–4000	425	440								
4001–4250	445	460								
End rail	23 mm	38 mm					50 mm			

Header dimensions are approximate values which may exhibit negative or positive deviations depending on the technical circumstances.

Vertical section: example of header

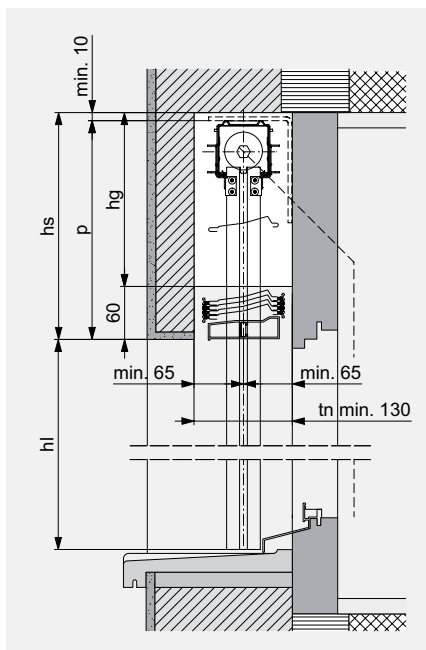

BUILT-IN SYSTEM



Top section: for crank drive

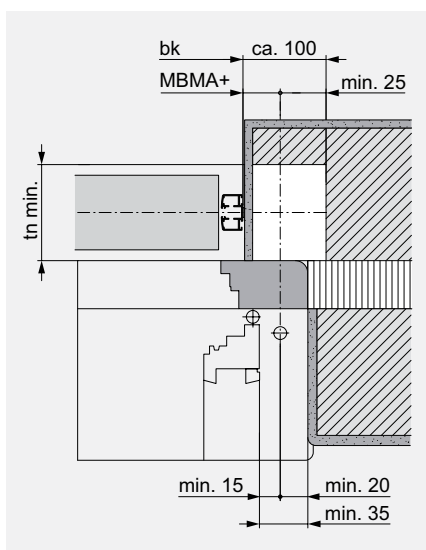

Top section for crank drive

With recess (white) for gearbox (not necessary for motor drive). MBMA+ = Dimension from rear edge of guide rails to center of drive. With gearbox in slat area: $hs + 20$ mm. A dimensional tolerance of ± 5 mm is observed for the header height.

Depth of niche

	tn
Grinotex®	min. 130*

* + possible addition for protruding weatherboard or doorknobs.

If crank drive is in slat area: maximum surface area and crank position available on request.



Vertical section: example with cover

FRONT MOUNTED SYSTEM

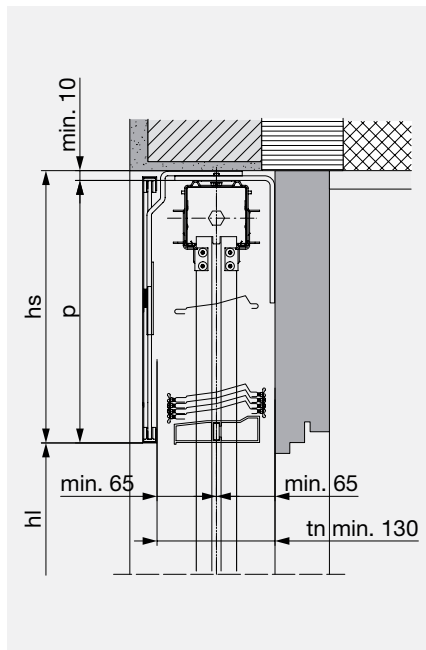

LATERAL GUIDE RAILS

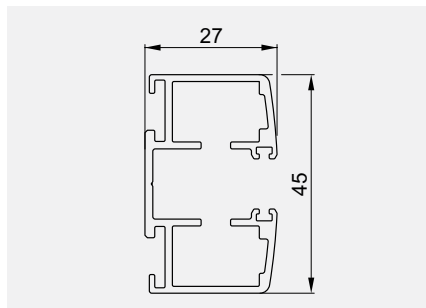

KEY

- bk = Width of construction
 - hl = Opening height
 - p = Height of package
 - hs = Header height (p + min. 10)
 - hg = Height of gearbox recess (hs -60)
 - tn = Depth of niche
- All dimensions in mm.





GriColor - 100 colors



BiColor

OPTIONS

Operating position

The shade produced when lowering the blinds is often annoying – particularly in the work place. The slat lowering position of around 48 degrees prevents the room from getting dark when the blind is lowered.

COLORS

GriColors

The GriColors range includes 100 color shades in four collections, Glass & Stone, Sun & Fire, Water & Moss and Earth & Wood – from cool white and sunny red to natural blue and earthy brown.

BiColor

External venetian blinds get a new color; when the outside of the slat is brightly colored, a neutral light tone on the inside can optimize the blind functions. The interior view shows the colors outside on the border edges. The guides and end rails are transparently anodized. Our color recommendations for Interior color: white (VSR901) light grey (VSR904) or medium grey (VSR130).



DESIGN DESCRIPTION

Blind system

Composite metal technology and guide pins on each individual slat give Grinotex® stability in high wind areas. Metal pivotal slat connections and steel cables coated with UV stable plastic lend added system durability. The lateral lifting mechanism operates using steel roller chains with an automatic safety locking feature in every position. A standard reversing edge prevents the blind from being damaged when it encounters obstacles in motion (up to 2250 mm in height). Although starting from a closed position, the slats can be adjusted between open and closed at every height.

The self-supporting

The self-supporting blind design preserves the insulation in the header and reduces service costs. The insulation remains intact and noise transfer is reduced. The stable guide rails 45 x 27 made from extruded aluminum feature service openings. Integrated guide rails are available on request.

Slats

The robust Grinotex® slat resists bending and twisting using rolled edge reinforcement and a plastic sealing lip that offers not only quieter operation, but provides an extra level of light control. Each 93 mm slat comes standard with a polyamide guide pin for smooth operation and greater system stability.

End rail made from extruded aluminum, transparently anodized (baked enamel finish for an additional charge).

Lateral guide rails

Made from extruded aluminum 45 x 27 mm, with weatherproof noise insulation inserts, transparently anodized (baked enamel finish for an additional charge).

Housing

Made from galvanized sheet steel, open at the bottom, with wind-stable slat adjustment mechanism.

Drive

The external venetian blinds are equipped with a 230 V 50 Hz motor drive or an articulated crank drive.

CONTROLS

Grinotex® can be operated through a variety of control systems, from a simple hand-held transmitter to a master control or a building management system, depending on the time, position of the sun and the weather.

PLANNING AND OPERATING INSTRUCTIONS

The instructions in the Technical Data Sheets are to be observed when planning the solar shading.

The solar shading systems should be retracted if it is windy.

The systems must not be operated if there is a risk of ice.

The systems must be accessible for maintenance work.

Observe the VSR data sheets or information in EN 13659 wind classes.



Grinotex® is available as a MINERGIE® module in an automated version.

Your partner

Subject to change without prior notice

